

	GLOBAL STANDARD	Page 1 of 28
	LV SWITCHBOARD FOR SECONDARY SUBSTATIONS	GSC002 Rev. 1 July 2020

LV SWITCHBOARD FOR SECONDARY SUBSTATIONS

Revision	Description
01	Second Emission – all DSOs adoption – Annex inclusion in main Technical Specification

Organization	Elaborated by	Verified by	Approved by
Global I&N – NT/NCS	M. Neri	M. Bartolucci	M. Mazzotti

	GLOBAL STANDARD	Page 2 of 28
	LV SWITCHBOARD FOR SECONDARY SUBSTATIONS	GSCL002 Rev. 1 July 2020

1	SCOPE	3
2	LIST OF COMPONENTS.....	3
3	REFERENCE LAWS.....	5
4	STANDARDS	5
5	SERVICE CONDITIONS.....	6
6	TECHNICAL CHARACTERISTICS	6
7	CONSTRUCTION CHARACTERISTICS.....	7
8	TESTING.....	19
9	SUPPLY REQUIREMENTS	23
10	ANNEX 1 – CLOSING PLATES FOR LV PANELS.....	24
11	ANNEX 2 – SUPPORT FOR LV PANEL.....	25
12	ANNEX 3 – EX DY3200 (EXTRACT OF THE SPECIFICATION)	28

	GLOBAL STANDARD	Page 3 of 28
	LV SWITCHBOARD FOR SECONDARY SUBSTATIONS	GSCL002 Rev. 1 July 2020

1 SCOPE

This Global Standard applies to LV Switchboard with 2 feeders with rated current up to 350 A, to be installed in secondary substations.

These Global Standard shall be used by all the DSOs of Enel Group listed below:

- Enel Codensa (Colombia)
- Enel Distribución Chile (Chile)
- Enel Distribuição Rio (Brazil)
- Enel Distribuição Ceará (Brazil)
- Enel Distribuição Goiás (Brazil)
- Enel Distribuição São Paulo (Brazil)
- Enel Distribución Perú (Perù)
- Edesur (Argentine)
- Edistribución Redes Digitales SLU (Spain)
- Enel Distribuție Banat (Romania)
- Enel Distribuție Dobrogea (Romania)
- Enel Distribuție Muntenia (Romania)
- E-distribuzione (Italy)

2 LIST OF COMPONENTS

Table 1 – Type Codes

TYPE CODE	Former Type Code	APPLICATION
GSCL002/1	ex DY 3010	2 CBs with rated current of 125 ÷ 250 A
GSCL002/2	ex DY 3011	2 CBs with rated current of 350 A
GSCL002/3	ex DY 3012	1 CB with rated current of 125 ÷ 250 A 1 CB with rated current of 350 A
CB = Circuit Breaker		

	GLOBAL STANDARD	Page 4 of 28
	LV SWITCHBOARD FOR SECONDARY SUBSTATIONS	GSCL002 Rev. 1 July 2020

Table 2 – Material Codes

Enel Group Distribution	Type code	GSCL002/1	GSCL002/2	GSCL002/3
Enel Codensa (Colombia)		163422	163423	-
Enel Distribución Chile (Chile)		160052	160053	160054
Enel Distrib. Ceará-Goiás-Rio (Brazil)		T160097	T160096	T160095
Enel Distribuição São Paulo (Brazil)		325099	325100	325142
Enel Distribución Perú (Perù)		-	¿	¿
Edesur (Argentine)		0107-0110	0107-0111	0107-0112
Edistribución Redes Digitales (Spain)		160303	160305	160304
Enel Distrib. B. – D. – M. (Romania)		160125	160126	160127
e-distribuzione (Italy)		160125	160126	160127

Switchboard shall be combined with spacer supports Annex 2 (always included in supply) and with disconnector Annex 3 (ex DY 3200) (opzional). Closing plates (Annex 1) are intended included in supply.

Some examples of possible combination between switchboards and CBs are listed in the next table:

Table 3 - Combinations

LV SWITCHBOARD	INSTALLABLE CIRCUIT BREAKERS		
Type	Number and type	Rated current (I_u) (A)	Neutral D = Disc. C = Cont.
GSCL002/1	2 x GSCL003/01 or GSCL003/19	250	D
	2 x GSCL003/02	180	
	2 x GSCL003/03 or GSCL003/20	125	
	2 x GSCL003/07 or GSCL003/21	250	C
	2 x GSCL003/08	180	
	2 x GSCL003/09 or GSCL003/22	125	
GSCL002/2	2 x GSCL003/15 or 2 x GSCL003/23	350	D
	2 x GSCL003/16 or 2 x GSCL003/24	350	C
GSCL002/3	1 x GSCL003/01 + 1 x GSCL003/15	250 - 350	D
	1 x GSCL003/19 + 1 x GSCL003/23	250 - 350	
	1 x GSCL003/07 + 1 x GSCL003/16	250 - 350	C
	1 x GSCL003/21 + 1 x GSCL003/24	250 - 350	

	GLOBAL STANDARD	Page 5 of 28
	LV SWITCHBOARD FOR SECONDARY SUBSTATIONS	GSCL002 Rev. 1 July 2020

3 REFERENCE LAWS

Switchboard shall comply with local regulations according to delivery destinations.

4 STANDARDS

The below listed reference documents shall be intended in the in-force edition at the contract date (amendments included). Unless otherwise specified, these documents are valid until the new editions replace them.

- IEC 61439-1 Low-voltage switchgear and controlgear;- general;
- IEC 61439-2 Low-voltage switchgear and controlgear - assemblies;
- IEC 61439-5 Low-voltage switchgear and controlgear - assemblies in public networks;
- IEC 60947-2 Low-voltage switchgear and controlgear – Circuit-breakers;
- IEC 60529 – Degrees of protection provided by enclosures (IP Code);
- IEC 62262 – Degrees of protection provided by enclosures for electrical equipment against external mechanical impacts (IK code);
- IEC 60695-11-10 - Fire hazard testing - Part 11-10: Test flames - 50 W horizontal and vertical flame test methods;
- IEC TR 61641 - Enclosed low-voltage switchgear and control-gear assemblies - Guide for testing under conditions of arcing due to internal fault;
- DJ 1203 – Prescrizioni per prova di invecchiamento artificiale accelerato in atmosfera umida materiale organico;
- GSCL003 – Automatic four-pole circuit-breakers with 40 A – 630A rated current for Sec. Substation;

	GLOBAL STANDARD	Page 6 of 28
	LV SWITCHBOARD FOR SECONDARY SUBSTATIONS	GSCL002 Rev. 1 July 2020

5 SERVICE CONDITIONS

Service conditions are the normal service conditions according to 61439-1, 61439-2 and 61439-5.

6 TECHNICAL CHARACTERISTICS

6.1 Ratings

- Rated Voltage:	400 V
- Rated current: GSCL001/1-2-3	500-700-650A
- Rated impulse withstand voltage phase-to-earth and phase-to-phase (switchboard without CBs and without LV auxiliary circuits):	20 kV
- Rated power-frequency withstand voltage phase-to-earth and phase-to-phase (switchboard without CBs and without LV auxiliary circuits)	10 kV
- Rated short time withstand current:	16 kA
- Rated Frequency:	50/60 Hz
- Degree of Protection IP:	3X
- Impact resistance IK:	08
- Pollution degree:	3

6.2 General Characteristics

The electrical scheme of the LV switchboard is shown in fig. 1:

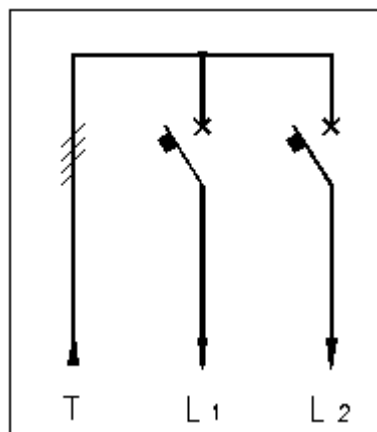

Fig. 1 – Electrical scheme

The switchboard is basically formed by a support equipped with a metallic or fiberglass plate (or other equivalent material) on which 2 CBs with related supply conductors are installed.

	GLOBAL STANDARD	Page 7 of 28
	LV SWITCHBOARD FOR SECONDARY SUBSTATIONS	GSCL002 Rev. 1 July 2020

In the following fig. 2 the switchboard is shown in frontal and lateral views where the overall dimensions are the same for all types of switchboard.

As below indicated the switchboards differ as far as the dimensions of the internal copper busbars are concerned; the fixing holes of the supplied plate can vary depending on the MCCB to be installed.

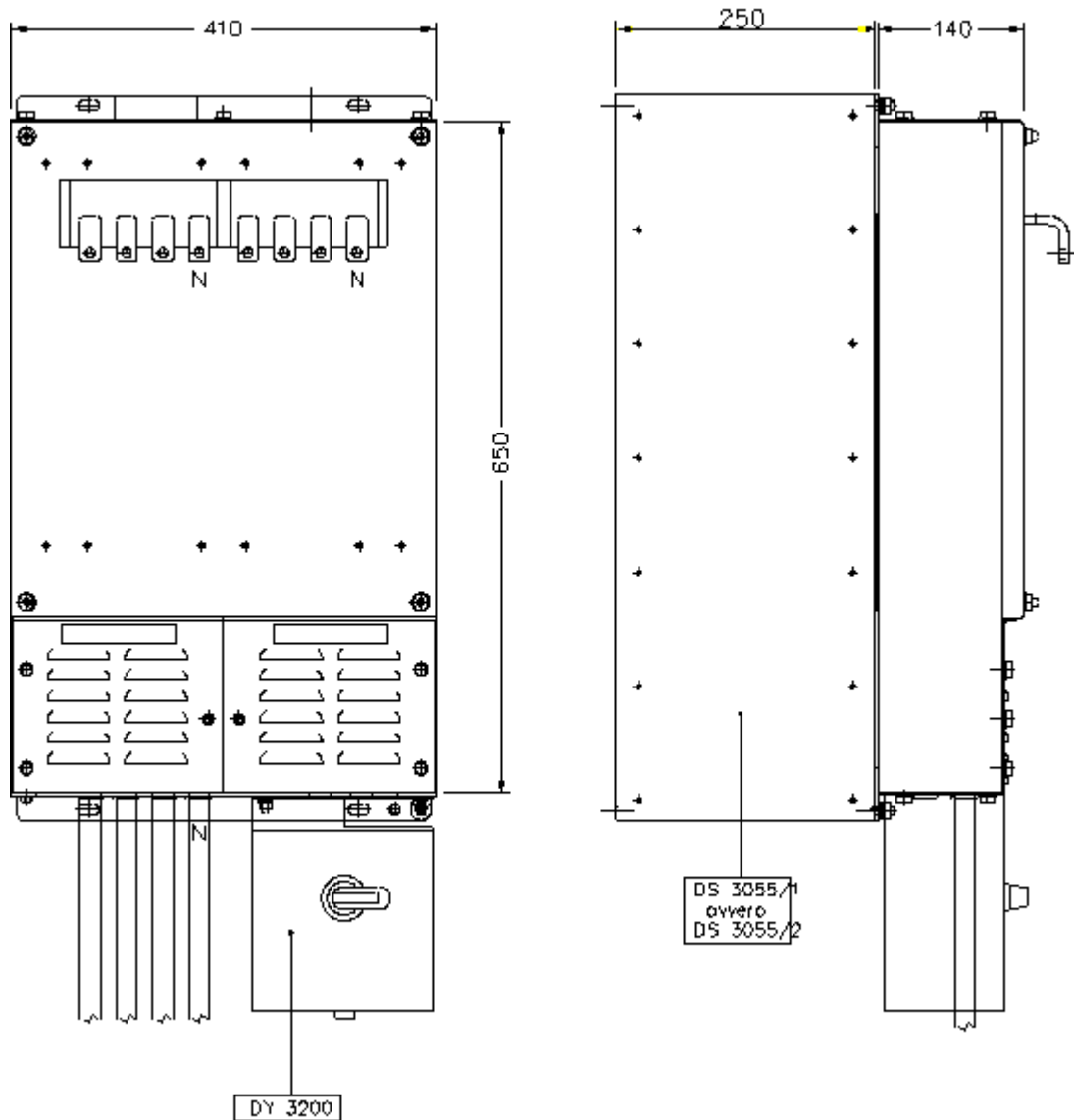

Fig. 2 – LV switchboard dimensions

7 CONSTRUCTION CHARACTERISTICS

7.1 General characteristics

The switchboard, metallic or fiberglass casing, shall be IP3X, excluding CBs bottom termination covers (area of connection of LV cables), for which an IP2X is acceptable.

Supplier can propose alternative solutions, functionally equivalent; these solutions shall be preliminarily approved by Enel.

	GLOBAL STANDARD	Page 8 of 28
	LV SWITCHBOARD FOR SECONDARY SUBSTATIONS	GSCL002 Rev. 1 July 2020

The closing plates (CBs up to 250 A and 350 A CBs respectively) must be mounted on the switchboard covering the CB fixing plate, in order to guarantee IP3X on the supply terminations (see Annex 1).

Threaded inserts shall be metallic and manufactured such as to prevent their extraction and rotation during CBs fixing.

7.2 LV CBs fixing plate

Each plate shall permit the installation of 2 standardized CBs (GSCL003) with rated voltage from 125 A to 350 A (see fig. 3).

The plate shall be equipped with copper rigid connections for the LV CBs supply; in case of metallic plate, connections shall be fixed on the standardized post insulators; in case of fiberglass plate, connections shall be rigidly fixed on the fiberglass structure.

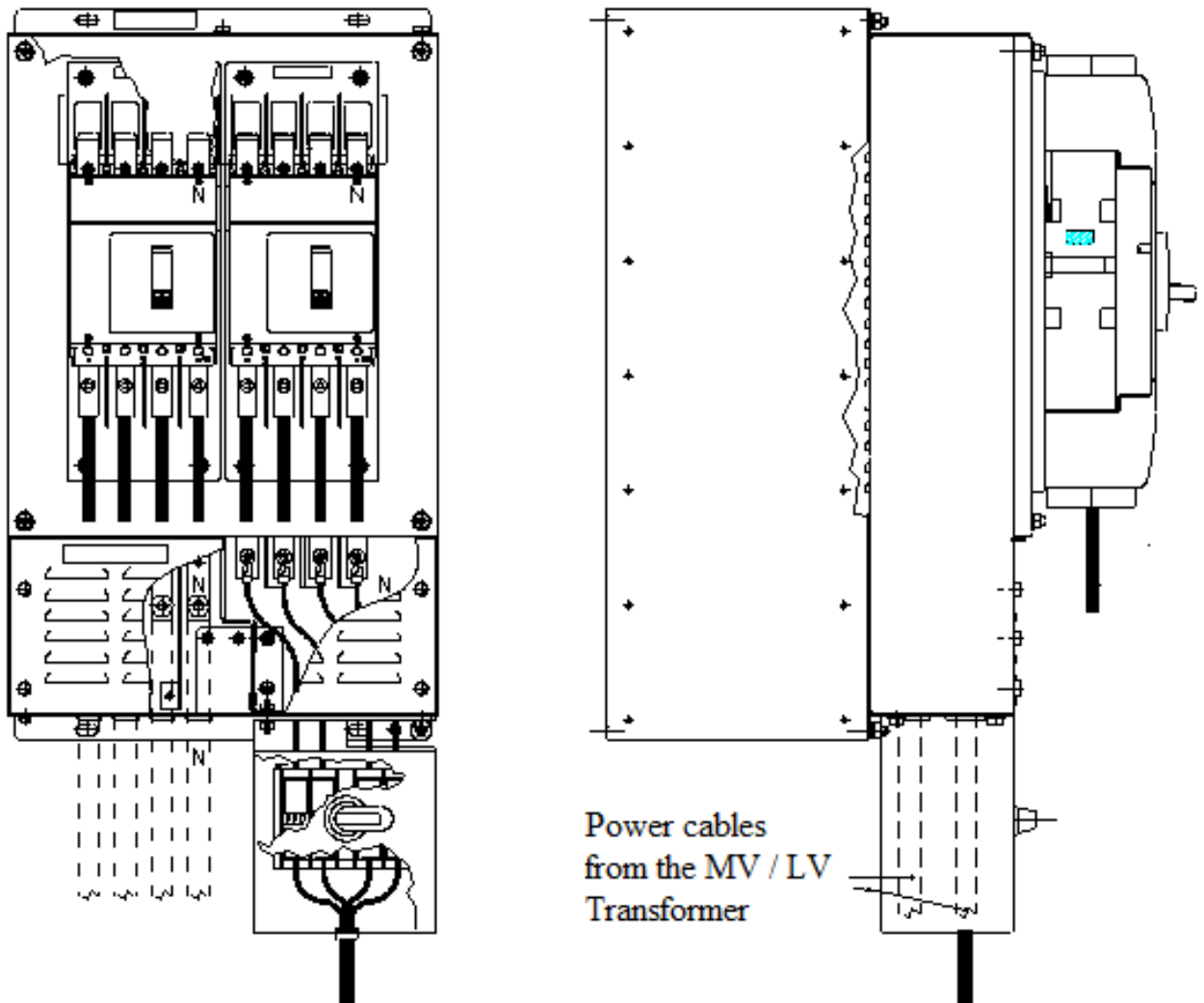
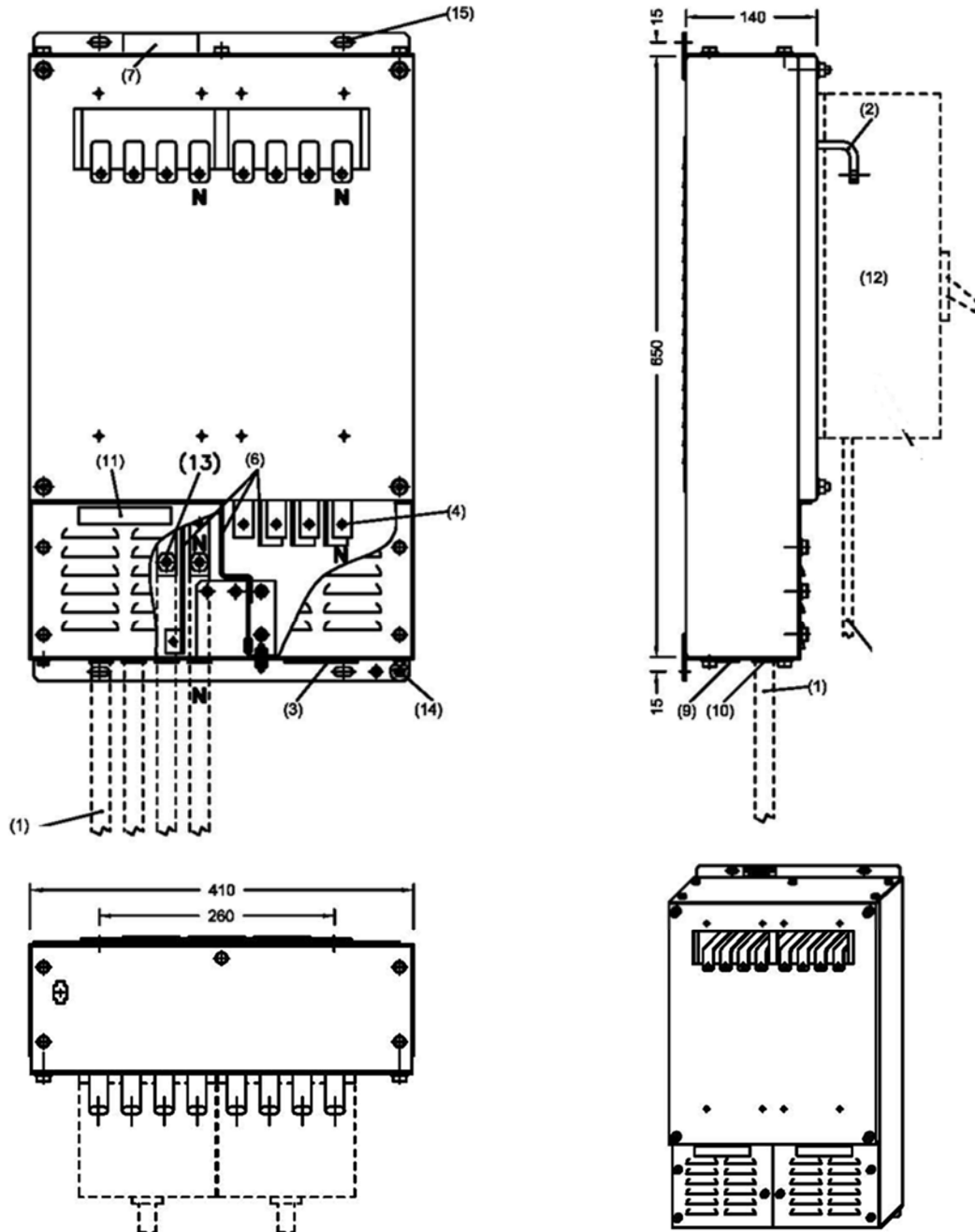

Fig. 3 – LV panel with installed breakers

7.3 GSCLO02/1 - LV switchboard for MCCBs from 125 to 250A



1) Power supply cables for connection to TR MT/LV	2) Bus bar Cu 20x6 mm
3) N. 4 diaphragm cable glands for cable with cross section of 25 mm ²	4) Power points for DY3200 (optional)
5) Deleted	6) Insulating separators between phases
7) Electrical panel plate	8) Deleted
9) N. 4 snap-on insulation caps	10) N. 8 cable bushings (n. 4 installed on the panel)
11) N. 2 warning plates	12) MCCB 125-180-250A
13) N. 8 cable lugs with contained connection (L19 - hole Ø10.5)	14) Grounding bolt
15) N. 4 sunshade 9x20 mm	

Fig. 4 – LV switchboard type: GSCLO02/1

This type of switchboard must allow the installation of MCCB from 125 to 250A requiring copper busbars (20x6 mm) with a distance of 35 mm as shown in fig. 5.

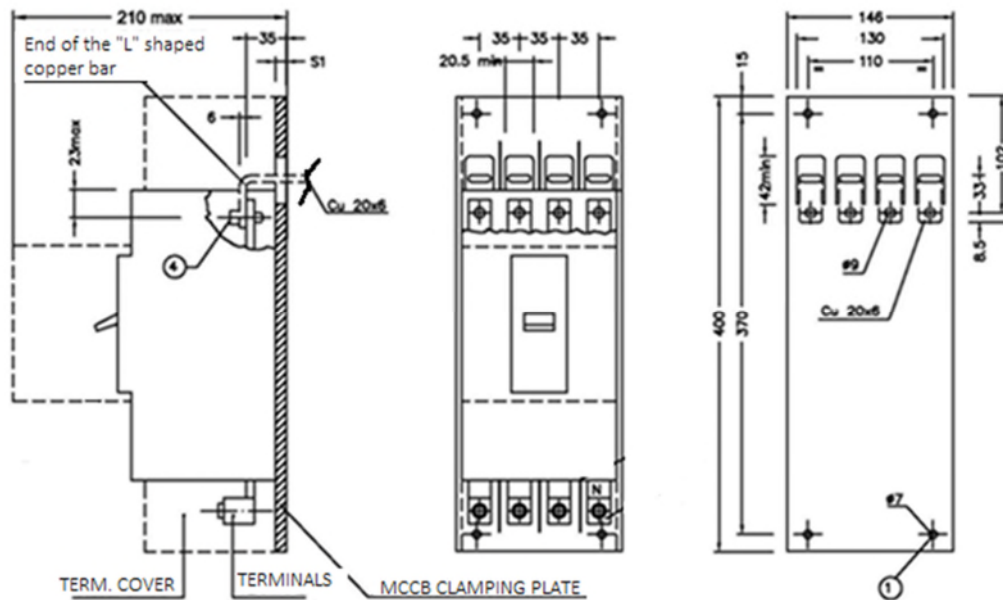

Fig. 5 – MCCB 125 ÷ 250A

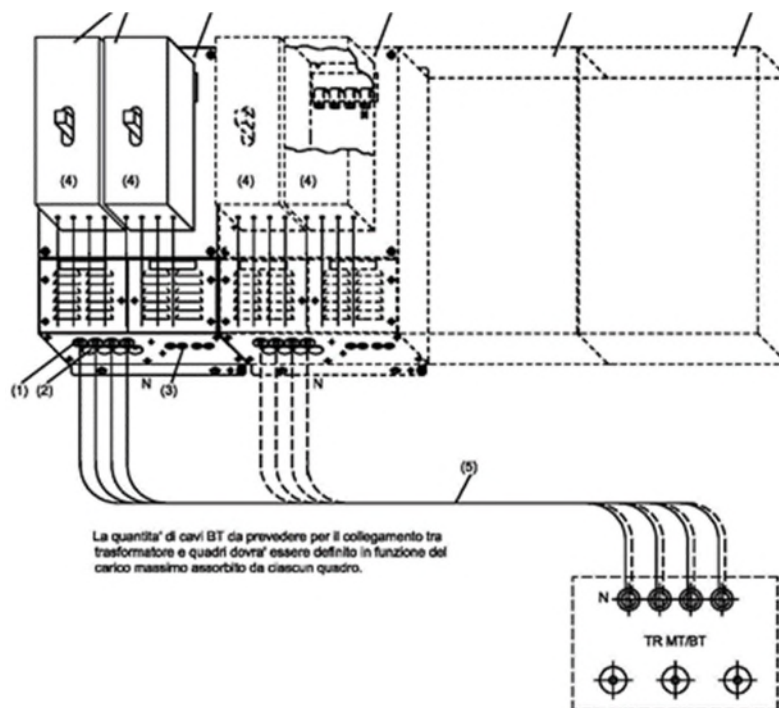

Fig. 6 – Example of connection to the transformer

7.4 GSCL002/2 – LV switchboard for MCCBs 350A

This type of switchboard must allow the installation of MCCB only 350A requiring copper busbars (30x8 mm) with a distance of 45 mm as shown in fig. 7:

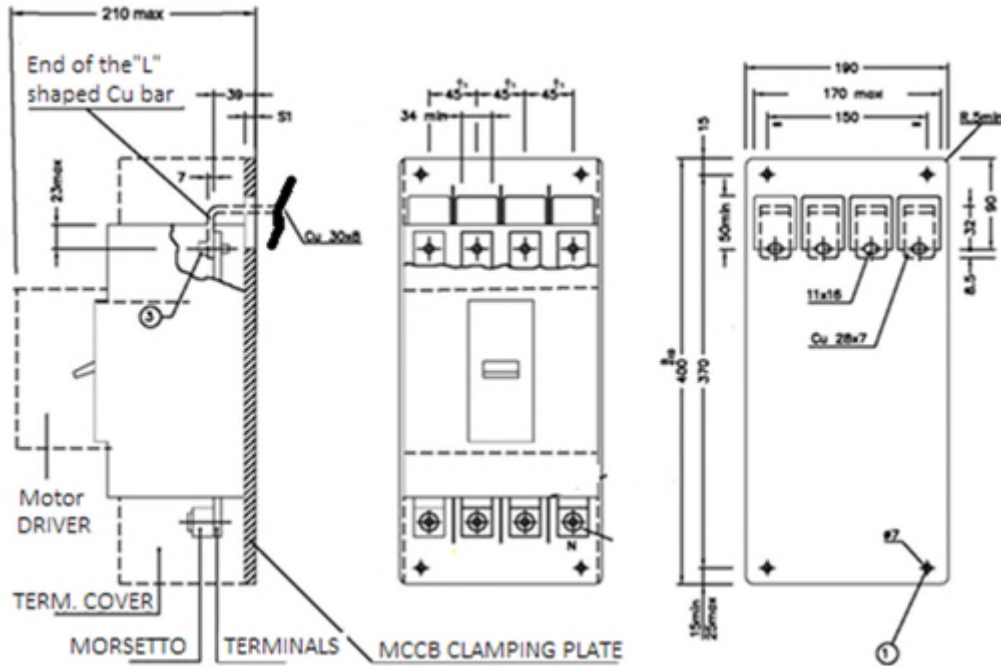

Fig. 7 – MCCB 350A

The following notes with reference to fig. 4 for the GSCL002/1 switchboard are updated as follows:

1) Power supply cables for connection to TR MT/LV	2) Busbar Cu 30x8 mm
3) N. 4 diaphragm cable glands for cable with cross section of 25 mm ²	4) Power points for DY3200 (optional)
5) Deleted	6) Insulating separators between phases
7) Electrical panel plate	8) Deleted
9) N. 1 snap-on insulation caps	10) N. 7 cable bushings
11) N. 2 warning plates	12) MCCB 350A
13) Deleted	14) Grounding bolt
15) N. 4 sunshade 9x20	

7.5 GSCL002/3 – LV switchboard for MCCBs 250 and 350A

On this type of switchboard installation of a 350 A breaker on the left side and a breaker up to 250 A on the right side shall be allowed as shown in fig. 8.

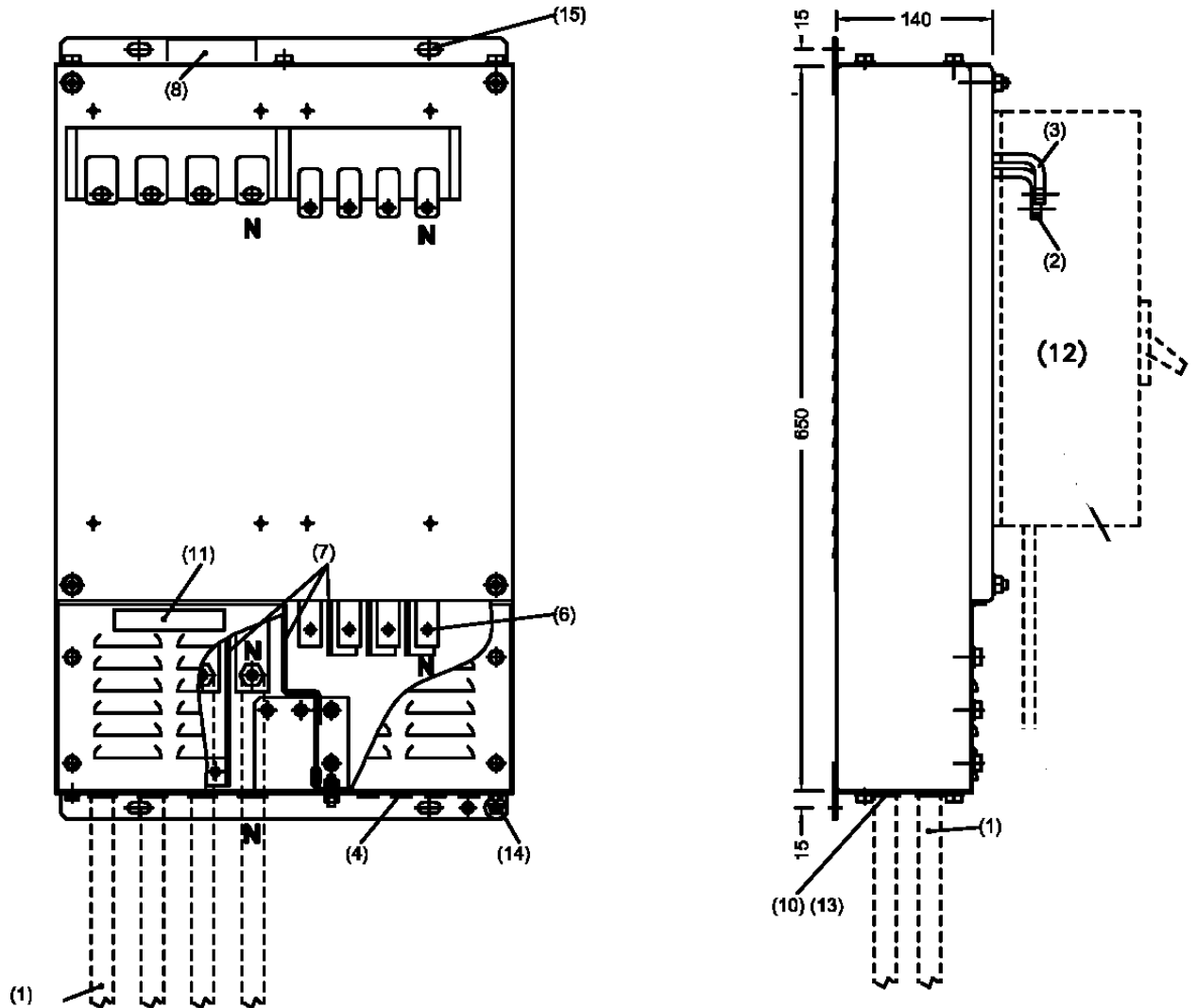

1) Power supply cables for connection to TR MT/LV	2) Busbar Cu 20x6 mm
3) Busbar Cu 30x8 mm	4) N. 4 diaphragm cable glands for cable with cross section of 25 mm ²
5) Deleted	6) Power points for DY3200 (optional)
7) Insulating separator between phases	8) Electrical panel plate
9) Deleted	10) N. 7 cable bushings
11) N. 2 warning plates	12) MCCB 350A and 250A
13) N. 1 snap-on insulation caps	14) Grounding bolt
15) N. 4 sunshade 9x20	

Fig. 8 – LV switchboard type: GSCL002/3

	GLOBAL STANDARD	Page 13 of 28
	LV SWITCHBOARD FOR SECONDARY SUBSTATIONS	GSCL002 Rev. 1 July 2020

7.6 Switchboard enclosure with ventilation grid on the bottom

The enclosure of the switchboard must have an aeration grid on the bottom having the purpose of disposing of the heat produced by the passage of current on the copper bars and that of giving vent to the energy that is produced in the event of an arc inside the switchboard. (see fig. 9)

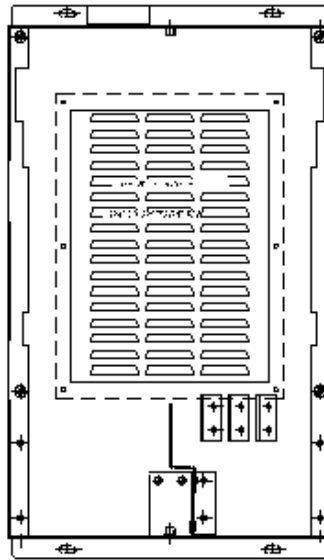

Fig. 9

7.7 Busbar connection for power cable connection

The panel must be equipped with a bolted door on the lower left side to access the copper bars for the connection of the cable terminations coming from the MV/LV transformer. The insulating separator between phases must be fixed to the door.



Fig. 10 – Power supply



Fig. 11 – Connection for Element for Auxiliary Switchboard derivation ex DY3200 - Annex 3

	GLOBAL STANDARD	Page 14 of 28
	LV SWITCHBOARD FOR SECONDARY SUBSTATIONS	GSCL002 Rev. 1 July 2020

7.8 Connection points for LV auxiliary cable

On the right side of the electrical panel there must be a connection point for the power supply of the disconnectable switch 400V 32A with 4 poles and a fuse support - Annex 3 (optional) see fig. 1. A cover, similar to the previous one shall be included.

7.9 Plate for identification, warning of danger

On the switchboard, for all the models, a plate shall be affixed. The following information shall be present on each plate:

- International Standard compliance (IEC 61439-5);
- Manufacturer name or trademark;
- ENEL group type;
- ENEL code manufacturer identification;
- Manufacturing year (at least last 2 figures).

Furthermore on the two covers, in the lower part of the switchboard, adhesive plates warning against voltage danger (as indicated in the construction drawings of the panel) must be present.

7.10 CB Mock up template

The CB mock up template ("DIME") proposed in figures 12 and 13 can be used to check the correct positioning of the copper bars for the connections of the MCCBs. The metal threaded inserts must be positioned on the plate to check the interchangeability of the MCCBs of different manufacturers.

DIMA PER IL CONTROLLO DEL POSIZIONAMENTO DELLE
CONNESSIONI TRA QUADRO BT E INTERRUTTORI FINO A 250 A

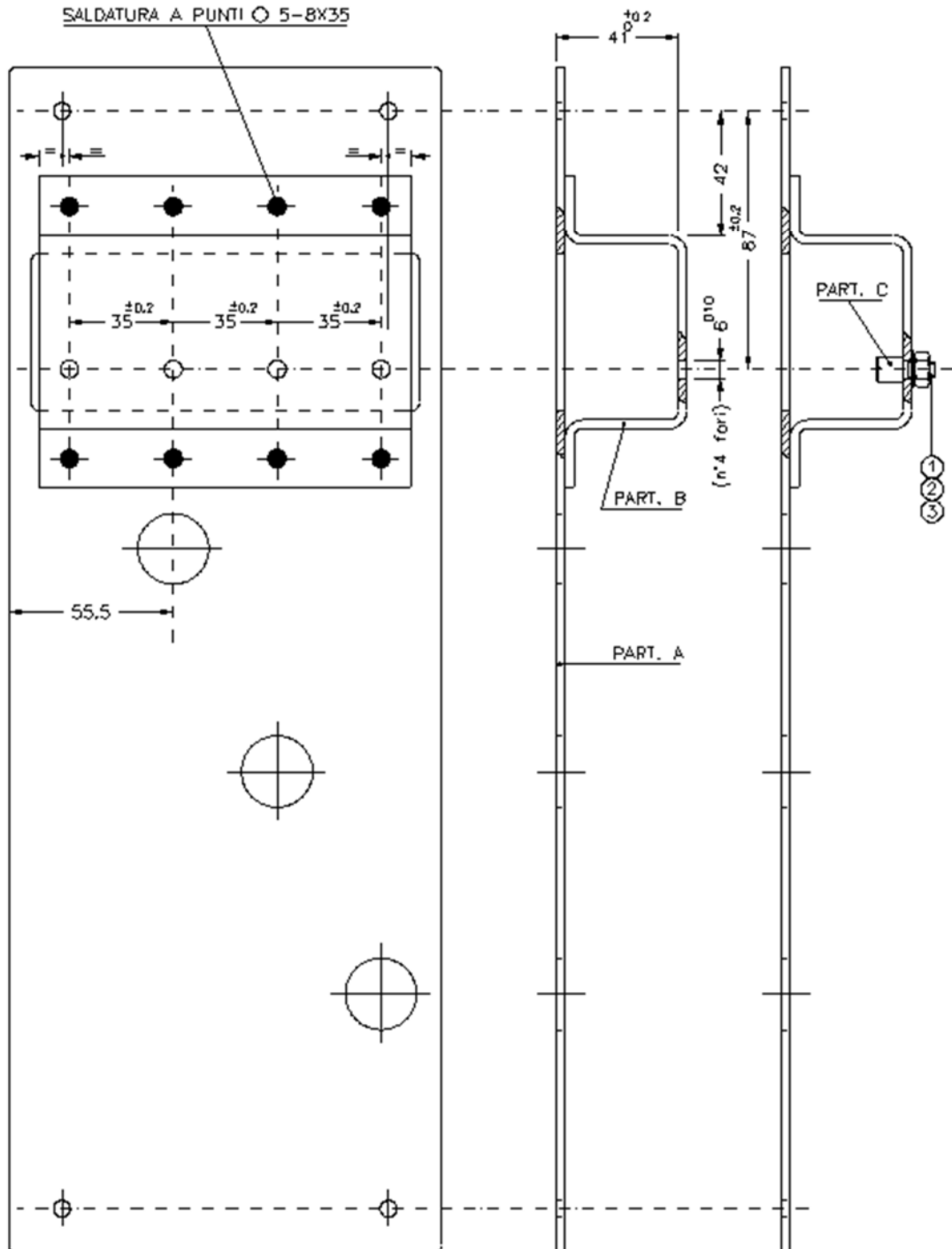

Finitura con zincatura elettrolitica UNI ISO 2081 e UNI ISO 4520 DOPO SALDATURA

- ① Dado M5 - UNI 5588-65
- ② Rosetta A 5,3-UNI 1751
- ③ Rosetta 5,3x10-UNI 6592-69-R40

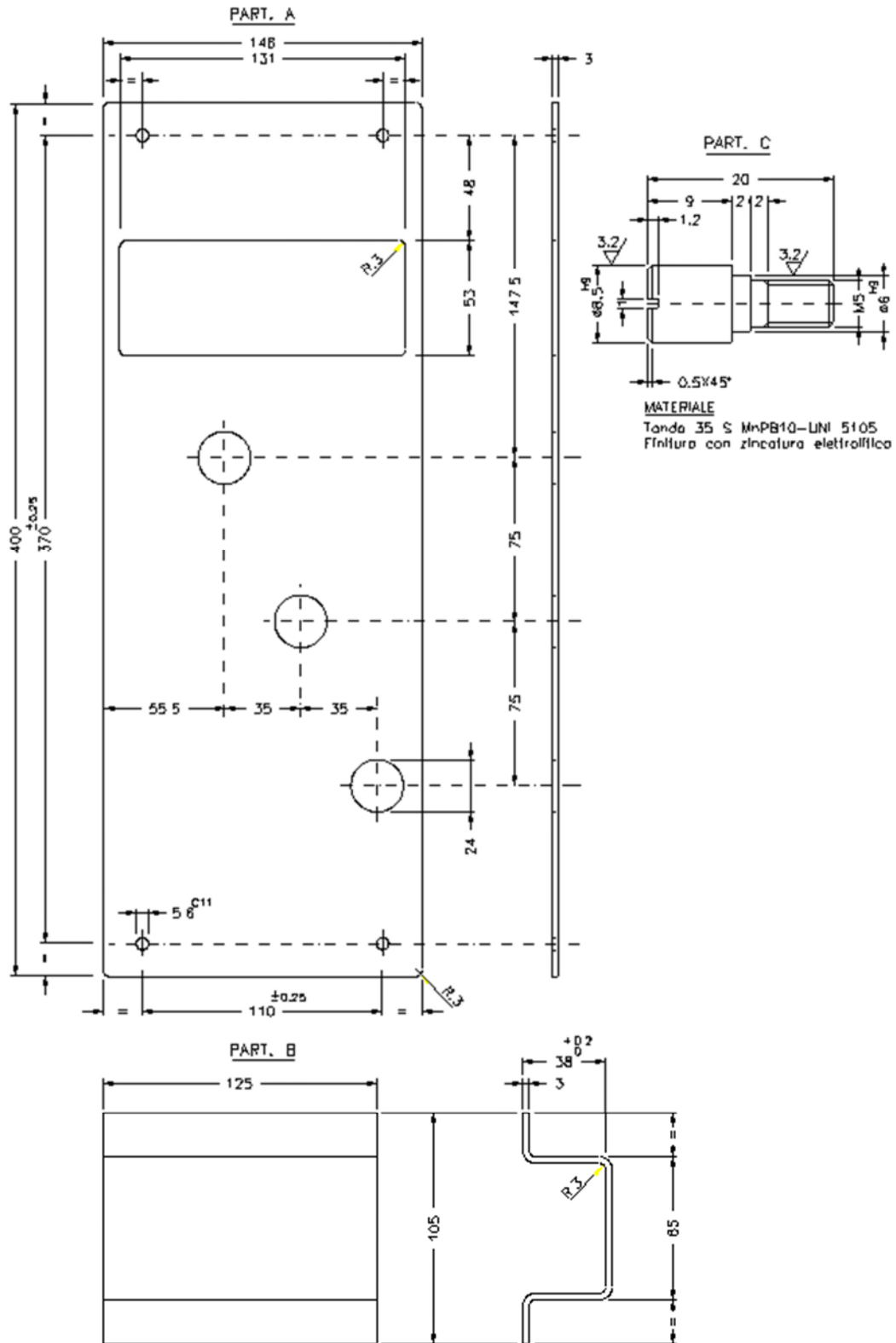
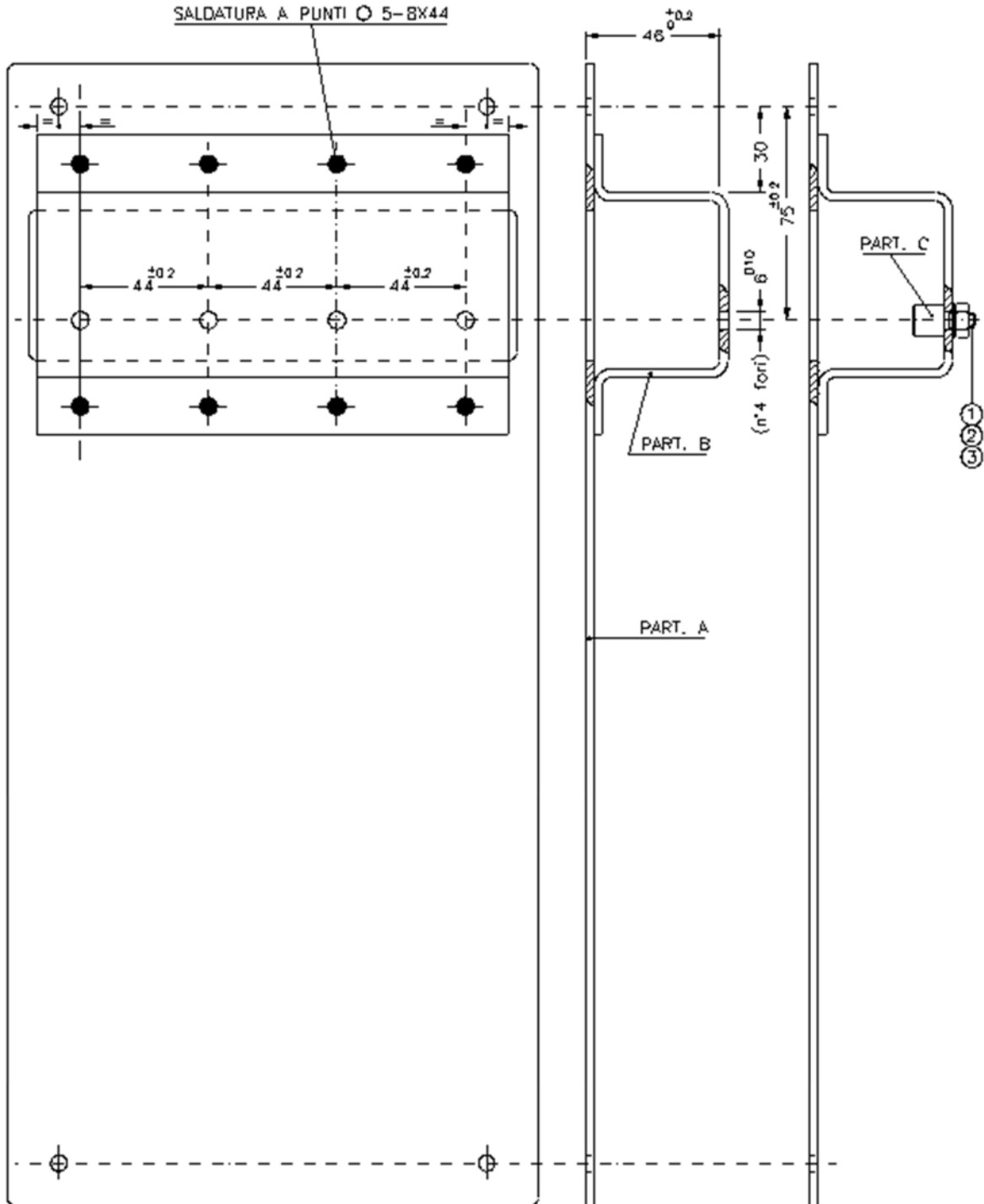

Fig. 12 – CB mock up for switchboard GSCLO02/1

DIMA PER IL CONTROLLO DEL POSIZIONAMENTO DELLE
CONNESSIONI TRA QUADRO BT E INTERRUTTORI DA 350 A

SALDATURA A PUNTI \varnothing 5-8X44



Finitura con zincatura elettrolitica UNI ISO 2081 e UNI ISO 4520 DOPO SALDATURA

- ① Dado M5 - UNI 5588-65
- ② Rosetta A 5,3-UNI 1751
- ③ Rosetta 5,3x10-UNI 6592-69-R40

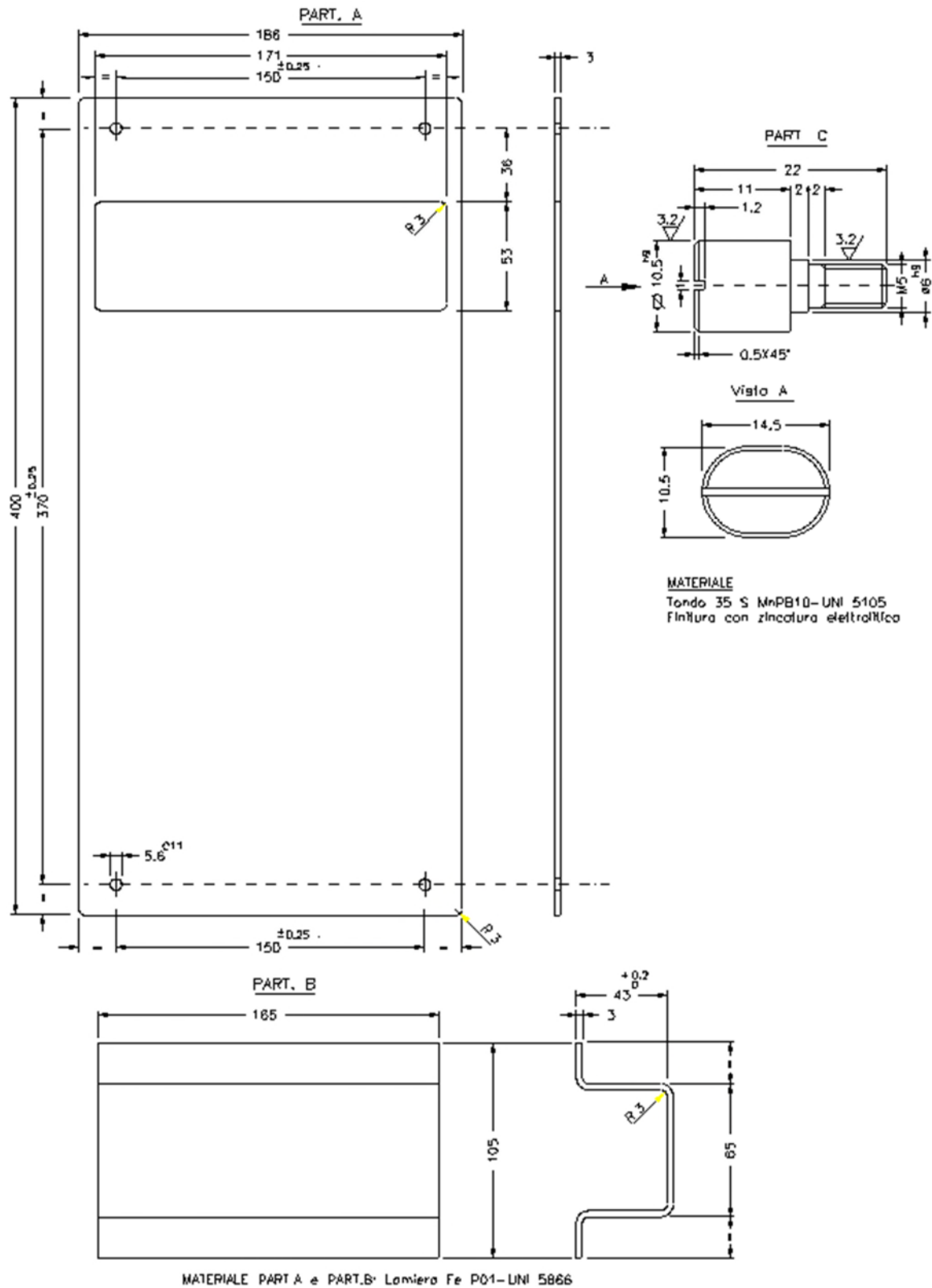

Fig. 13 – CB mock up for switchboard GSCL002/2

	GLOBAL STANDARD	Page 19 of 28
	LV SWITCHBOARD FOR SECONDARY SUBSTATIONS	GSCL002 Rev. 1 July 2020

8 TESTING

Unless otherwise specified in the following paragraphs, the switchboard shall be subjected to the design verifications given in chapter 10 of the standards IEC 61439-1, IEC 61439-2 and IEC 61439-5.

For the evidence cited in the following document, in brackets are the corresponding paragraph numbers of test related to IEC 61439-1.

The tests are divided into:

- **Project verifications** – that are designed to ensure the total conformity of an exemplary production (prototype) with the requirements contained in this document during the activities of approval / certification.
- **Routine tests** - conformity test made on each individual item during or after manufacture
- **Acceptance tests** – contractual test to prove to the customer that the item meets certain conditions of its specification.

8.1 Project verifications

8.1.1 Visual inspection (8.5)

It is necessary to inspect a switchboard of each type, to verify that the switching devices installed comply with the requirements listed in this specification, in particular should be checked:

- panel dimensions and presence of accessories indicated in the previous paragraph 8;
- presence of all identification plates, warning of danger;
- materials used, according with construction drawings and the documentation presented by the manufacturer. For this purpose, the manufacturer must show the origin certificates of the materials used; in absence of such certificates, Enel reserves the right to carry out mechanical tests and chemical analyzes on samples taken from finished products to ascertain the exact compliance of the materials used with the prescribed;
- positions and dimensions of the holes provided for fixing the panel using the control measurements (see chapter 8) or alternatively, by mounting on the switchboard at least two MCCBs of different manufacturers (according to GSCL003);
- presence of all components required and their compliance with IEC reference (IEC 61439-1 par. 8.5.3).

8.1.2 Strength of materials and parts of the control panel (10.2)

The suitability of mechanical, electrical and thermal processing of building materials and parts of the switchboard are considered proven with the checks on its construction and performance described below (IEC 61439-1 and IEC 61439-5 par. 10.2).

- Check of corrosion resistance performing test Severity B par. 10.2.2.3 IEC 61439-1 (alternatively, tests previously executed according old DJ 1203 can be accepted subjected to Enel examination for a maximum of 2 year time since specification issuing, subjected to Enel approval).
- Verification of resistance of material used to abnormal heat and fire, due to internal electrical effects, in accordance with the requirements of point 10.2.3.2 of standard IEC 61439-1. The flammability category shall correspond to the requirements of point 10.2.3.102 of standard EN 61439-5.
- Thermal stability of the enclosure in compliance with the requirements of point 10.2.3.1 of standard IEC 61439-1 and point 10.2.3.101 of standard IEC 61439-5 (alternatively tests previously executed according old DY 3508 a.1.2 can be accepted for a maximum of 2 year time since specification issuing, subjected to Enel approval).
- In addition, all plastic elements or any other non-metallic material forming an integral part of the enclosure of the switchgear, maneuvering equipment or fuse bases must be classified in category V-0 according to standard IEC 60695-11-10 (method B).

	GLOBAL STANDARD	Page 20 of 28
	LV SWITCHBOARD FOR SECONDARY SUBSTATIONS	GSC002 Rev. 1 July 2020

- Verification of the degree of protection against external mechanical impacts (10.2.6). The panels must withstand an impact of 10 joules with IK 09 according to IEC 62262 and IEC 61439-5 par 10.2.101.7; the separation fins between the phases must be tested by means of impacts deriving from percussion forces applied to the ends of the same with energy equal to 1.5 Joules. Verification is carried out by placing the element under test on a reference plane and making it adhere to three points; it must be verified that at no point is there a deviation greater than 2 mm from the surface
- Marking (10.2.7).

8.1.3 Degree of protection provided by enclosures (10.3)

Fully equipped panels (each type) must undergo the verification of the degree of protection (IEC 61439-1 par. 10.3) in accordance with standard IEC 60529; the degree to check is IP3X; (area of connection of LV cables IP2X is acceptable).

8.1.4 Insulation and creep distance (10.4)

Insulation and creep distances shall comply with IEC 61439-1 par. 10.4. In particular insulation clearance and creep distances specified in Annex F of IEC 61439-1 Pollution Degree 3 must be respected.

8.1.5 Insulation protection against electric shock and integrity of protective circuits (10.5)

The effectiveness of connection of the protection circuit is verified by passing the tests below:

- Verification of the continuity of the grounding between the masses and the protection circuit (10.5.2): connection to the protective earth of all the masses of the switchboard must be checked, connection must have a resistance $\leq 0.1 \Omega$.
- Short circuit withstand strength of the protective circuit (10.5.3.1): verification by test according to 10.11.5.6 IEC 61439-1.

8.1.6 Internal electrical circuits and connections (10.7)

Compliance with the design requirements for internal circuits and connections must be confirmed by visual examination and verified according to the IEC standard.

8.1.7 Terminals for external conductors (10.8)

Compliance with the design requirements for terminals for external conductors must be confirmed by visual examination.

8.1.8 Verification of dielectric properties (10.9)

Industrial frequency (50/60 Hz) voltage for one minute:

- 10 kV between the active parts and between joined together and the metal mass of the frame. In case of panels with insulating shells, a metal sheet placed on the outer surface shall be used as a mass (10.9.2 and 10.9.4).
- 20 kV Impulse withstand voltage of 1.2/50 μ s.
Between the active parts and between active parts and metallic mass, 3 pulses of negative polarity and 3 pulses of positive polarity of 20 kV of peak value shall be applied. In case of an insulating envelope, the mass is formed by a metallic sheets that, for this specific test, shall be placed covering the outer surface of the enclosure of the frame (10.9.3 and 10.9.4).

	GLOBAL STANDARD	Page 21 of 28
	LV SWITCHBOARD FOR SECONDARY SUBSTATIONS	GSCL002 Rev. 1 July 2020

8.1.9 Verification temperature rise (10.10.2)

Verification by carrying out the effective test (with current flowing over temperature limits foreseen by Table 6 quoted in par. 9.2 of IEC 61439-1 shall not be exceeded).

The test must be carried out on the panel completely set up as per ordinary use, using the following test configurations:

- 1) simultaneously feeding the three phases;
- 2) simultaneously powering the two single-phase and independent circuits thus created:
 - neutral pole in series with the pole of the most distant phase;
 - the two intermediate phases connected in series.

8.1.10 Short-circuit withstand (10.11)

Short-circuit withstand must be tested performing the test described in paragraph 10.11.5 of IEC 61439-1 for 16 kA. Test shall be performed applying rated current in most critical point according to specific design of manufacturers.

The test results according par. 10.11.5.5 and 10.11.5.6.2. of standard

8.1.11 Internal electric arc test

To carry out the test, reference should be made to the IEC 61641 technical report, with the clarifications indicated below.

The LV switchboard under test must be completely set up as per ordinary use and mounted on the support frame as per Annex 2 (ex DS 3055 specification) ; on the panel the closing plates must be assembled as per Annex 1 (ex DY 3003 table) . The three-phase power supply must be connected to the input circuit terminals via a copper cable for phase of 150 mm² section. The neutral conductor and the metal casing of the switchgear must be earthed. The indicators for the thermal effects of the gases must be arranged vertically on the front side of the object under test and must be positioned up to a height of 2 m. and for a width of 1 m., at a distance of 30 cm from the panel itself. Indicators shall be made up of pieces of black cotton fabric of about 150 g / m² and, for the test, they must be stretched and enclosed in a steel frame of dimensions 150 mm x 150 mm.

The arc must arise from a symmetrical short-circuit on the busbars of the switchboard by means of a bare copper wire with a section of 0.75 mm² and must be characterized by an effective current value of 16 kA (40 kA of ridge) with an equal duration at 0.3 s.

The outcome of the test is to be considered positive if all the five criteria established in the IEC 61641 technical report are met, where applicable.

8.1.12 Torsion resistance test of screw connections

The following test procedures apply to all screw connections.

To check the resistance to twisting of the connections, the screws must be inserted, screwed in deeply, loosened and removed five times; the test must be carried out by continuously and without tearing, with a torque wrench, the torque required as in table below.

Nominal diameter of the screw (mm)	Tightening torque (Nm)
4- 6	3
8	6
10	10
12	15

Table 4

At the end of the test it must be verified that the inserts have not undergone any variation with respect to the initial position, that it is possible to unscrew, remove and re-tighten the screws without any difficulty and that the elements made of insulating material containing the inserts have not been damaged, cracked or detached from the plan.

8.1.13 Zinc plating verification

The verification must be carried out according to what reported in the EN ISO 2081:2018.

8.2 Routine tests

All the switchboards produced must be subjected to the tests indicated in IEC 61439-1 chapter 11.

8.3 Acceptance tests

All tests except the 13.1 described below, must be made on a representative sample of the lot, as prescribed in the ISO 2859-1 for sampling plan simple reduced AQL = 0.65%.

The size of the sample is defined as the total number of switchboards of GSCL002/1-2-3.

8.3.1 Visual inspection (8.5)

It is necessary to inspect a switchboard of each type, to verify that the switching devices installed comply with the requirements listed in this specification, in particular should be checked:

- The switchboard under verification (and all components installed in it) shall correspond to the documents described according to TCA Dossier (available for viewing at manufacturer premises).
 - the dimensions of the panel and the presence of accessories indicated in the previous chapter 7;
 - presence of all identification plates, warning of danger;
- In particular, the positions and dimensions of the holes provided for fixing the panel and the correct positioning must be verified using the control measurements (see dimes chapter 8) or alternatively, by mounting on the switchboard at least two MCCBs of different manufacturers (according to GSCL003).

8.3.2 Verification of dielectric properties (10.9)

Industrial frequency (50/60 Hz) voltage for one minute:

- 10 kV between the active parts and between the active parts joined together and the metal mass of the frame.

8.3.3 Checking the tightening torque of the screws

On the screws that fix the bars it must be checked that the value of the tightening torque is between 20 Nm and 25 Nm.

The test must be performed on the derivations, on the 3 phases and on the neutral.

8.3.4 Zinc plating verification

The verification must be carried out according ISO 2081 standard

9 SUPPLY REQUIREMENTS

The switchboard shall be supplied in individual packages of cardboard boxes, such as to ensure a suitable protection during transport and storage.

The support for LV Panel – Annex 3- type DS3055/1 (stainless steel) shall be included in supply by default while the aluminium support DS3055/2 is intended as optional.

Closing plates (Annex 1) shall be also included in each LV switchboard supply.

The box containing the control panel shall include all elements and accessories required in the supply, in particular, each package should contain:

9.1 Type GSCL002/1

- The switchboard fully assembled according fig. 4 and Annex 4.
- Closing plates – Annex 1
- n. 4 diaphragm cable glands for cable with cross section of 25 mm²;
- n. 4 snap-on insulation caps (installed on the panel);
- n. 8 cable bushings (n. 4 installed on the panel);
- n. 8 cable lugs (L19 - hole Ø10.5) for 150 mm² cable (see fig. 12);
- Instructions for installation in the appropriate language;
- Declaration of conformity according to IEC 61439-5;

9.2 Type GSCL002/2 and GSCL002/3

- The switchboard fully assembled according fig. 8 and Annex 5 and 6.
- Closing plates – Annex 1
- n. 4 diaphragm cable glands for cable with cross section of 25 mm²;
- n. 4 snap-on insulation caps (installed on the panel);
- n. 8 cable bushings (n. 4 installed on the panel);
- Instructions for installation in the appropriate language;
- Declaration of conformity according to IEC 61439-5;

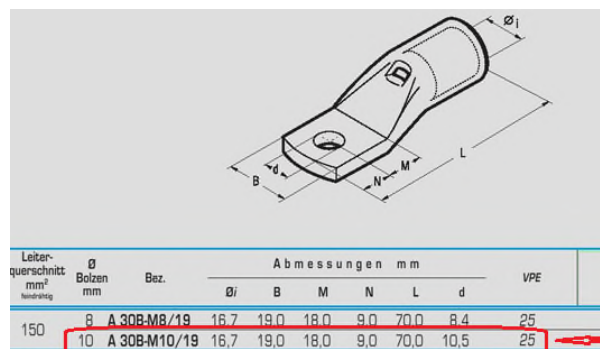

Fig. 14 – cable lugs for 150 mm² cable

On each transport packaging, on two adjacent faces, shall be reported, with readable characters:

- Name of the supplier
- Product Description
- ENEL type and serial number of the product
- Gross weight of a single package

10 ANNEX 1 – CLOSING PLATES FOR LV PANELS

Enel
DISTRIBUZIONE

SECONDARY SUBSTATIONS
CLOSING PLATE FOR LV PANELS
IN THE ABSENCE OF MCCB

16 01 C
DY 3003
2002 - December
Ed. 3 - 1/1

NUMBER	TYPE	MCCB	A	B	C	D
16 01 95	3003/1	125/180/250 A	146	110	50	40
16 01 96	3003/2	350 A	190	150	55	30

SEZ. A - A (DY 3003/1)

SEZ. A - A (DY 3003/2)

1- Material: polyester reinforced with glass fiber (SMC) of black color RAL 8022;

2- The plate must be stiffened with ribs 3 vertical and 3 horizontal 3 mm thick; on it must bear the name of the manufacturer; it must also include the danger of electrocution sign drawing;

3- Each plate it must be accompanied by n. 4 socket head screws M5 x 18 UNI 6107-67 and n. 4 spring steel washers 5.3 x 11 DIN 137;

4- Acceptance tests:
Inspection and dimensional check: on a randomly selected plate of each batch submitted for testing must verify the absence of defects (cracks, deformation, internal, burns, lack of materials and anything else that could affect the use of the plate) and the correspondence with the requirements.
ENEL reserve to require the manufacturer documentation to verify the suitability of the raw materials used for molding and also reserves, for the same purpose, the right to request at any time checks and / or professional examinations;

5- Unit: number of samples (n)

Esempio di Descrizione ridotta:
P.I.A.S.T.R.A. C.H.I.U.S.U.R.A. Q.U.A.D.R.O. B.T. C.A.B. S.E.C. U.E.

11 ANNEX 2 – SUPPORT FOR LV PANEL

	SECONDARY SUBSTATION		
	Support frame for panel BT DY3009	DS 3055	
		2002 - December Ed. 3 - 1/3	

DS 3055/1

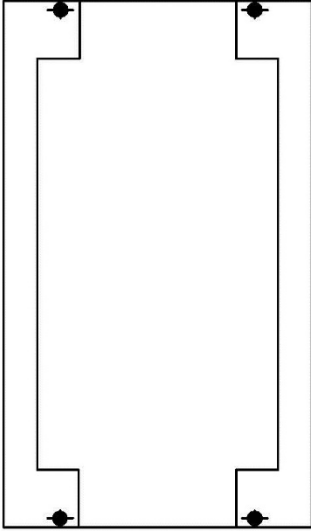

DS 3055/2

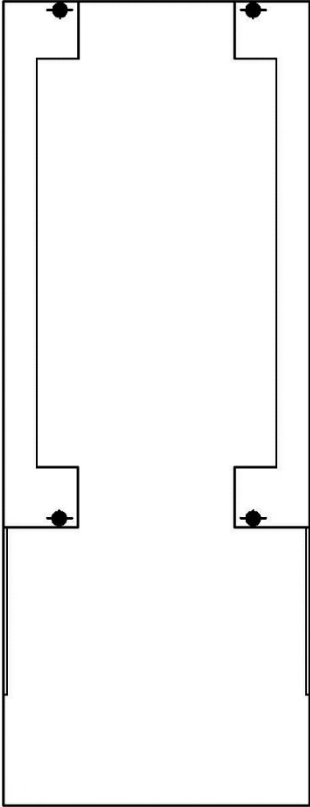

Table	Number	XXXXXX	Material	Weight
DS 3055/1	16 06 50	steel	pre-galvanized metal thickness 1,5 mm	~ 14 Kg
DS 3055/2	16 06 51	aluminum	metal thickness 5 mm	~ 27 Kg

Example short description

TELAIO SUPPORTO QUADRO BT :x:x:x:x:x:x

INGEGNERIA - UNIFICAZIONE



DS 3055
2002 - December
Ed. 3 - 2/3

DS 3055/1

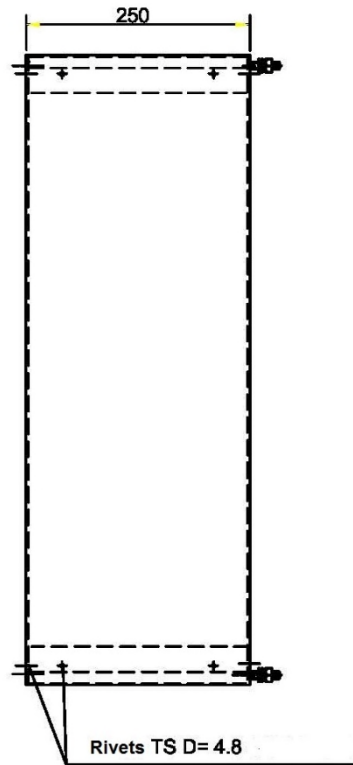
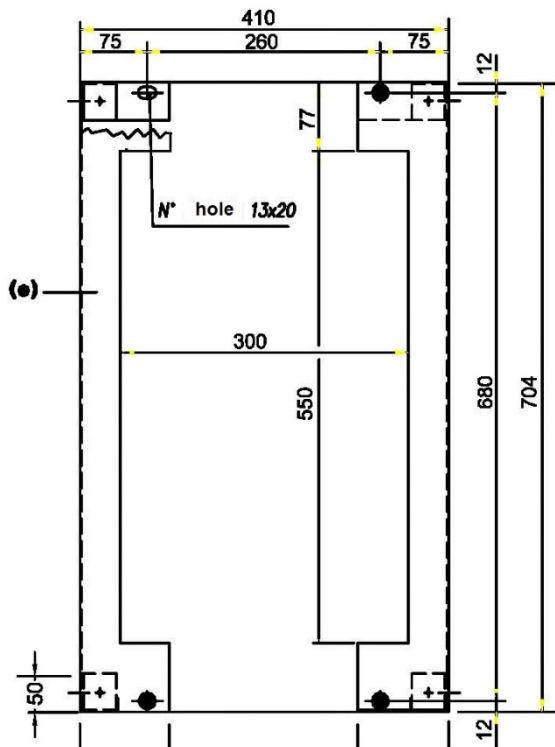

INGEGNERIA - UNIFICAZIONE

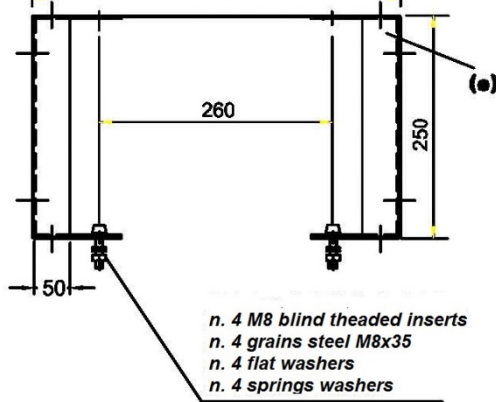

Steel pre-galvanized th. 1,5 mm
UNI EN 10142 RIVES.>200g/m

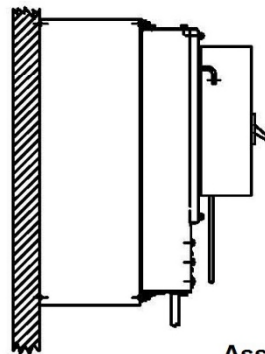

Assembly Drawing

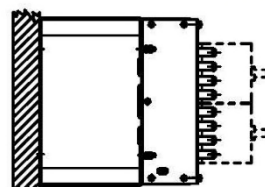



DS 3055

2002 - December
Ed. 3 - 3/3

DS 3055/2

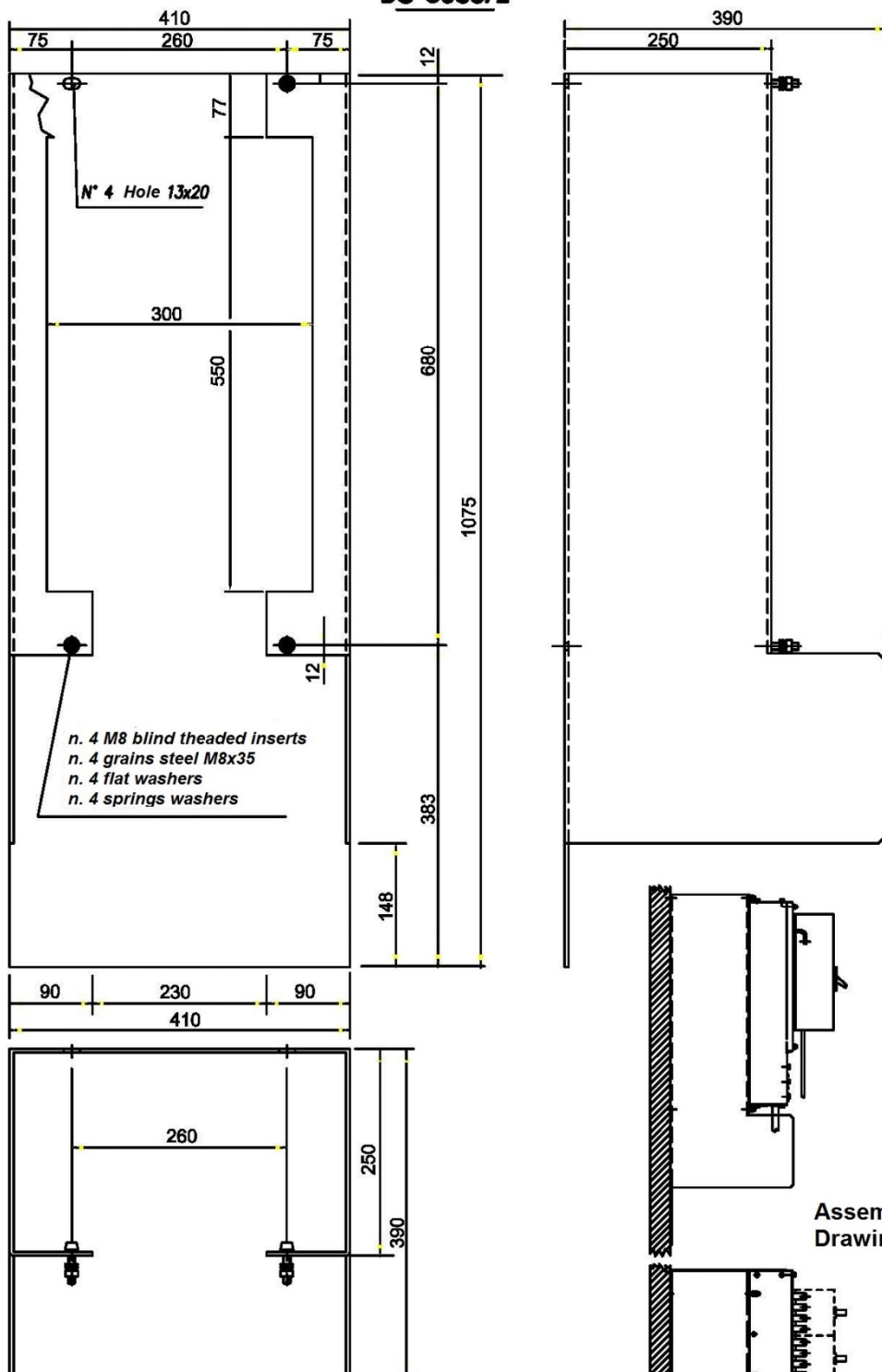

Alluminum th. 5 mm

Assembly
Drawing

12 ANNEX 3 – ELEMENT FOR AUXILIARY SWITCHBOARD DERIVATION (EXTRACT OF THE EX 3200 SPECIFICATION)

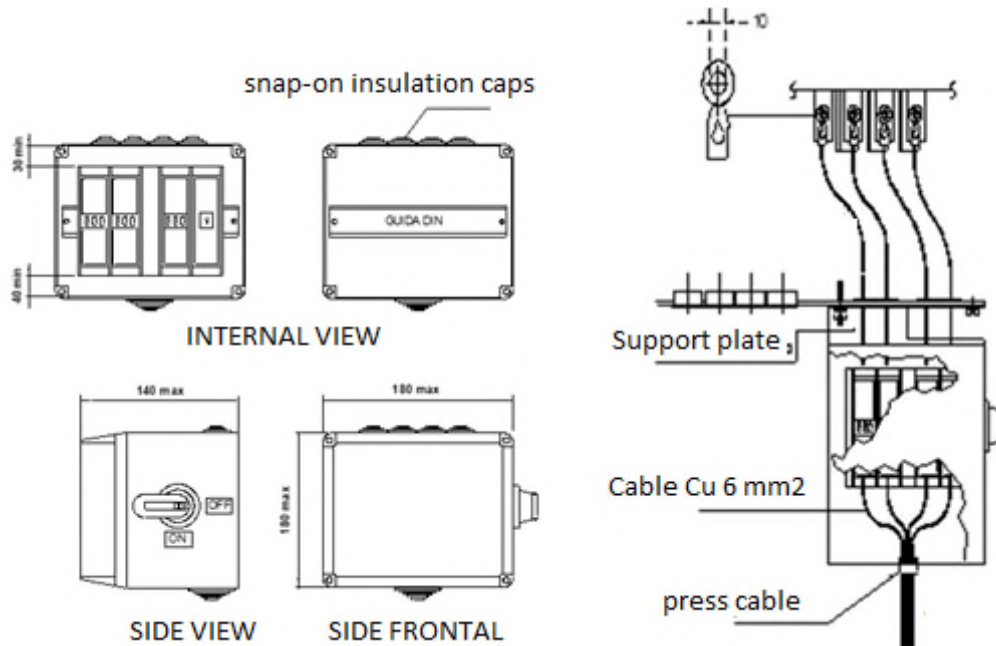

SUPPORT PLATE

Material

Lamiera Fe P12 UNI 5867 Sp 20/10

Treatment

Fe/Zn 12 C UNI ISO 4520 e UNI ISO 2081

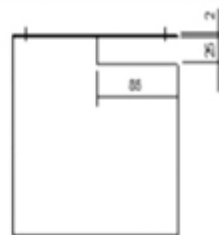

FRONTAL VIEW

